

# Future Energy Challenge 2005

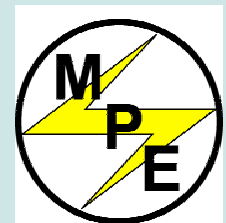

# A Few Hints

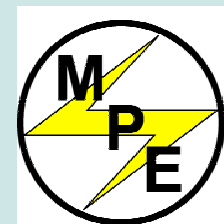

# DC to DC Converter

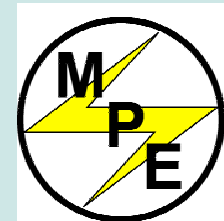
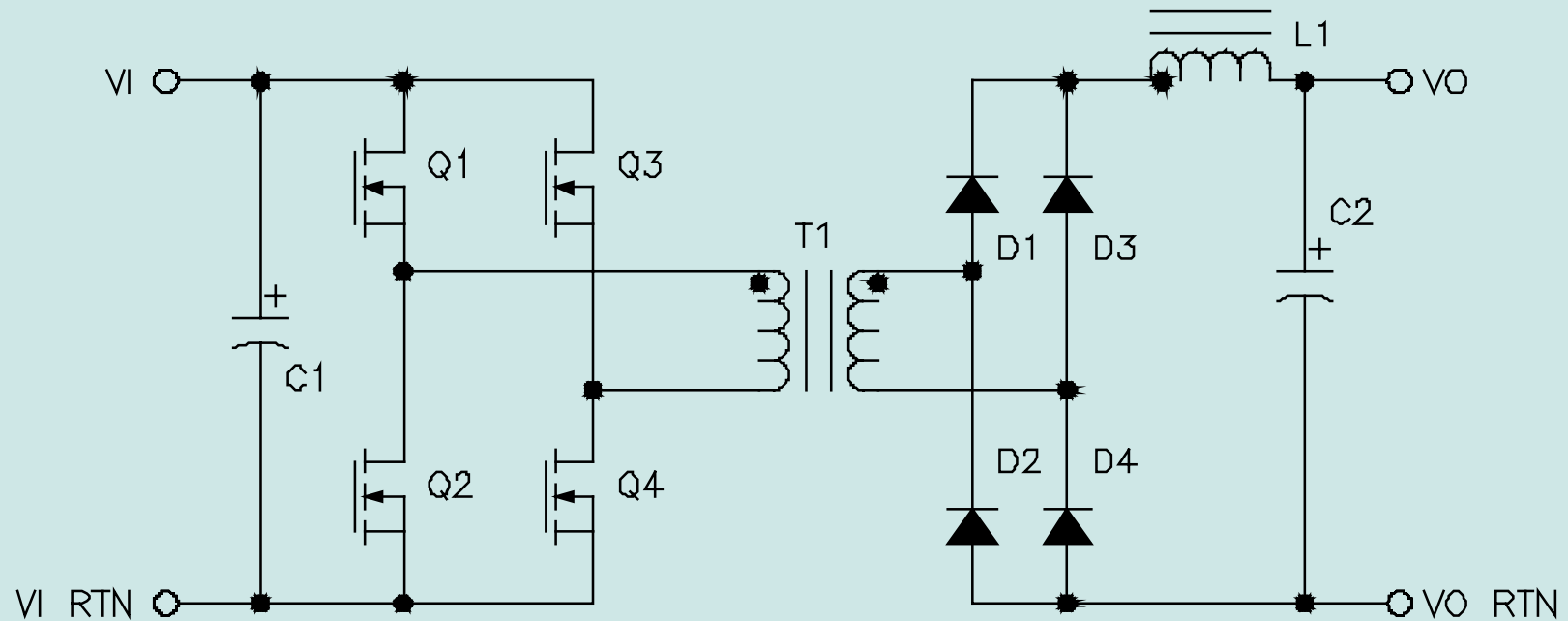

# DC to DC Converter with Troublesome Parasitic Components

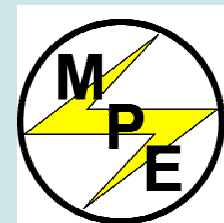
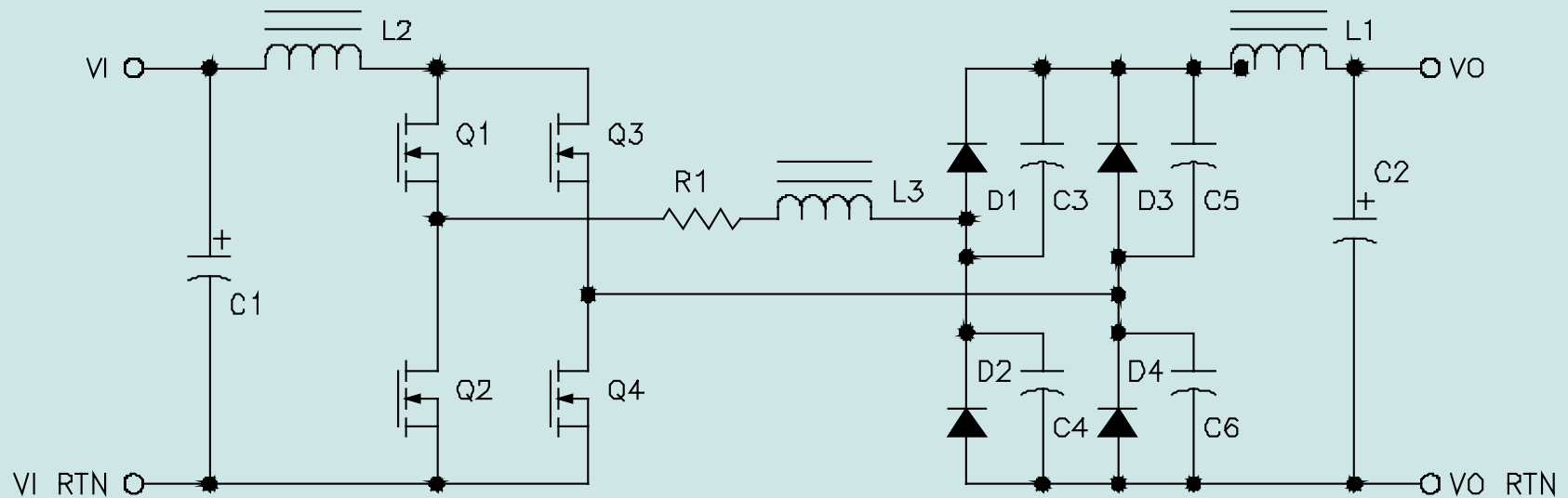

# Key Items to Address

- ◆ Protection of semiconductors
- ◆ Parasitic inductance between capacitors and switching devices
- ◆ Skin effect on conductors
- ◆ Leakage inductance in transformers
- ◆ Proximity effect and skin effect in transformers
- ◆ Reverse recovery time of diodes
- ◆ Cooling of semiconductors
- ◆ Ground loops
- ◆ Isolation between power and control circuit
- ◆ Isolation between primary, secondary, and ground circuits
- ◆ AC/DC voltages and currents in passive components

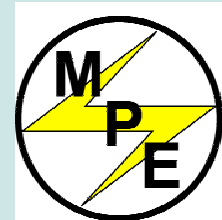

# 15 kW, 200 V to 28V, DC to DC Converter

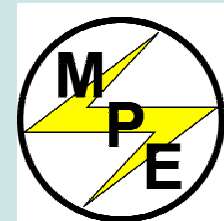
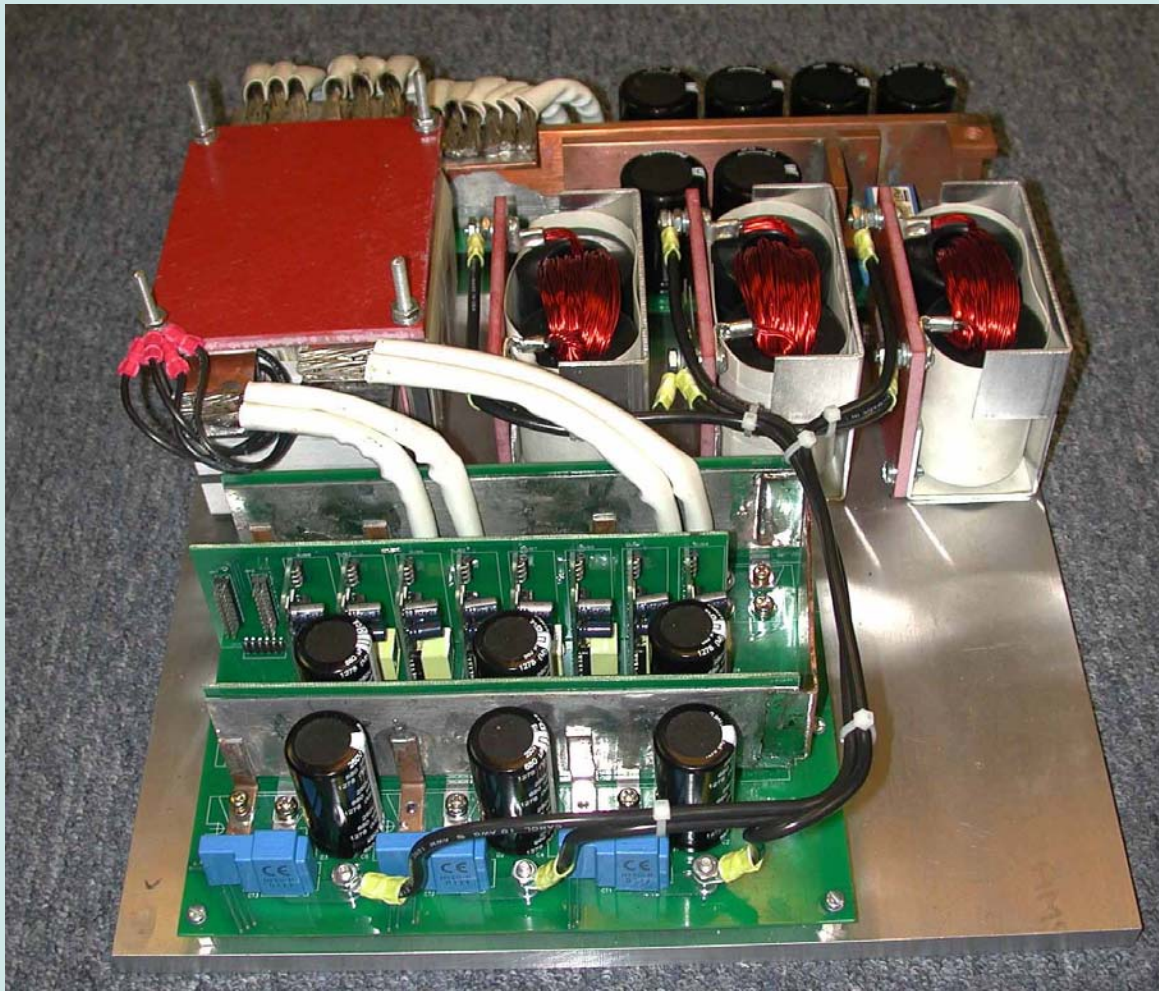

# Cost Estimating

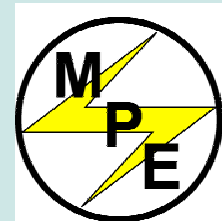

# Estimating Cost

- ◆ There are many factors to purchasing electronic materials. Actual cost evaluation is beyond the scope of the competition.
- ◆ Preliminary, relative cost estimates will be performed by each team using the spreadsheets evaluation forms presented here. The spreadsheet evaluation will give each team an “apple to apple” comparison
- ◆ Final cost estimates will be accomplished by submitting a bill of materials to a manufacturer. The manufacturer will then use their system for estimating the cost of the product.
- ◆ Only the winning team will have their design evaluated for cost by a manufacturer.

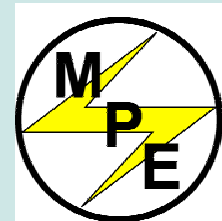

# Cost Estimates Using Electrical Ratings

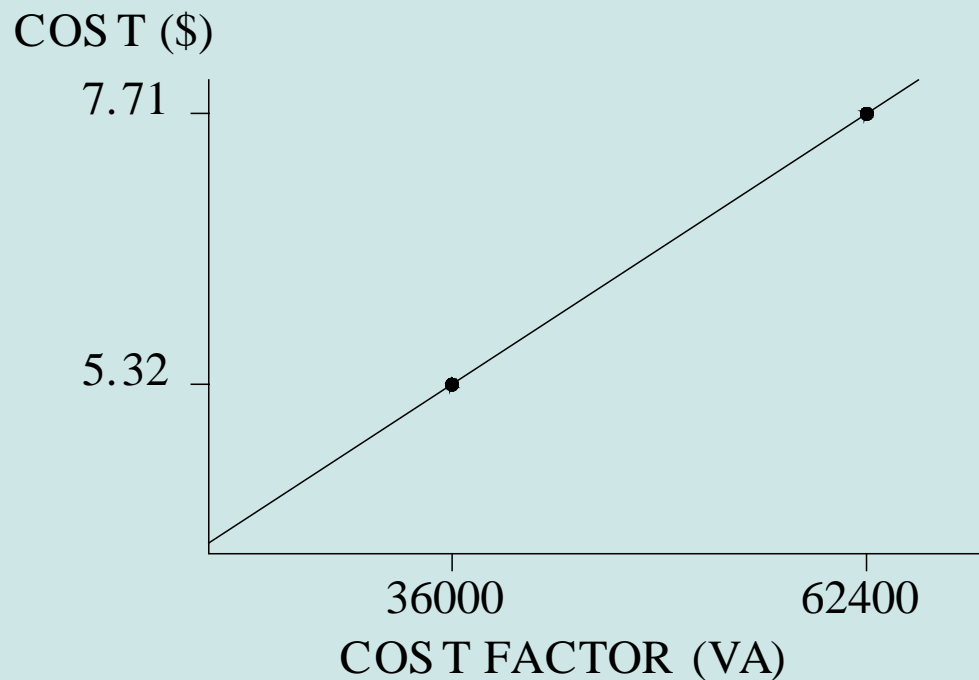

DEVICE	VOLTAGE RATING	CURRENT RATING	COST FACTOR	COST
DIODE A	600 V	60 A	36000 VA	\$5.32
DIODE B	1200 V	52 A	62400 VA	\$7.71

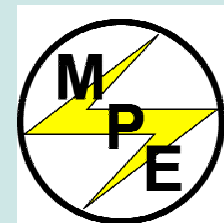

# Spreadsheet Example

2003 FUTURE ENERGY CHALLENGE										
UNIVERSITY: XYZ UNIVERSITY										
NAME OF MAIN CONTACT: TIPPYTWO										
PROJECT NAME: PESC INVERTER										
DATE: 09/27/2002										
DEVICE	QTY	DESIG	UNI	MEASURE	VOLT (Vpk)	VOLT (Vrms)	CUR (Avg)	CUR (Arms)	UNIT COST	EXTENDED COST
DIODE	2	D1,2			600		60		5.32	10.64
DIODE	2	D3,4			1200		30		5.32	10.64
DIODE										
DIODE										
DIODE - DUAL MODULE	2	D5,6			600		60		11.80	23.60
DIODE - DUAL MODULE	2	D7,8			600		60		11.80	23.60
IGBT	4	Q1,2,3,4			1000		34		13.56	54.24
IGBT	1	Q5			1000		100		39.66	39.66
IGBT										
IGBT										
IGBT										
IGBT										
TRANSISTOR	1	Q6			80		10		0.48	0.48
TRANSISTOR										
TRANSISTOR										
TRANSISTOR										
TRANSISTOR										
MOSFET										
MOSFET										
MOSFET										
MOSFET										
MOSFET - SINGLE MODULE	1	Q7			500		48		27.31	27.31
MOSFET - SINGLE MODULE	1	Q8			500		48		27.31	27.31
SCR	1	SCR1			600		70		4.68	4.68
SCR										
SCR										

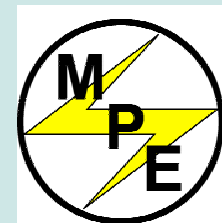

# Spreadsheet Example Con't

CAP (ALUM)	2 C1,2	1000 uF	450			28.14	56.28
CAP (ALUM)	1 C3	2000 uF	100			2.87	2.87
CAP (ALUM)	1 C4	4000 uF	100			5.64	5.64
CAP (ALUM)							
CAP (ALUM)							
CAP (ALUM)							
CAP (ALUM)							
CAP (FILM)	4 C5,6,7,8	0.1 uF	600			0.80	3.19
CAP (FILM)	1 C9	1 uF	250			0.92	0.92
CAP (FILM)	1 C10	4 uF	250			1.78	1.78
CAP (FILM)							
CAP (FILM)							
CAP (FILM)							
POWER RESISTOR	1 R1	50 W				2.64	2.64
POWER RESISTOR	1 R2	50 W				2.64	2.64
POWER RESISTOR							
POWER RESISTOR							
POWER RESISTOR							
POWER RESISTOR							
CHOKE	2 L1,2	200 UH			12.9	42.38	84.77
CHOKE							
CHOKE							
CHOKE							
CHOKE							
TRANSFORMER	1 T1			200	60	19.48	19.48
TRANSFORMER							
TRANSFORMER							
CONTACTORS							
CONTACTORS							
LOSSES		300 W				25.00	25.00
CONTROL							85.47
PACKAGING							64.10
OTHER (EXPLAIN)							
TOTAL							576.94

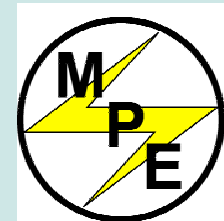

# Database Input

DATABASE INPUT												
	PART A						PART B					
DEVICE	PARM1	UNIT	PARM2	UNIT	COST A	FACTOR A	PARM1	UNIT	PARM2	UNIT	COST B	FACTOR B
DIODE	60	A	600	V	5.32	36000.00	52	A	1200	V	7.71	62400.00
DIODE - DUAL MODULE	60	A	600	V	11.80	36000.00	60	A	1000	V	14.30	60000.00
IGBT	20	A	600	V	4.86	12000.00	34	A	1000	V	13.56	34000.00
IGBT - DUAL MODULE	20	A	600	V	4.86	12000.00	34	A	1000	V	13.56	34000.00
TRANSISTOR	10	A	80	V	0.48	800.00	1	A	400	V	0.30	400.00
MOSFET	13	A	500	V	7.30	6500.00	26	A	500	V	10.80	13000.00
MOSFET - SINGLE MODULE	106	A	200	V	26.45	21200.00	48	A	500	V	27.31	24000.00
SCR	10	A	600	V	1.11	6000.00	70	A	600	V	4.68	42000.00
CAP (ALUM)	1000	UF	200	V	5.64	40.00	220	UF	450	V	6.27	44.55
CAP (FILM)	1	UF	250	V	0.92	0.06	4.7	UF	250	V	1.98	0.29
POWER RESISTORS	25	W			1.84	25.00	50	W	W		2.64	50.00
CHOKE	200	UH	73	A	101.00	1.07	1800	UH	12.9	A	57.50	0.30
TRANSFORMER	100	A	270	V	36.00	27000.00	1	A	212	V	6.50	212.00
CONTACTORS	30	A	240	VAC	8.04	7200.00	50	A	480	VAC	20.20	24000.00
LOSSES	300	W			25.00	300.00	600	W			50.00	600.00

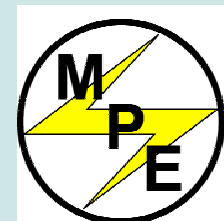

# Hints to a Successful Project

## -- Lessons Learned from the 2003 Future Energy Challenge

- ◆ Review requirements before designing circuits.
- ◆ Work as a team.
- ◆ Look at the technical objectives first. A low cost system means nothing if it does not work.
- ◆ Evaluate your project under worst case conditions before you come to the competition.
- ◆ Check out the thermal performance. Make sure your design works for hours rather than seconds.
- ◆ Good luck!

